

S.50-610

Ideal for dairy, vegetables, poultry, snacks, sweets and other industries that handle products requiring drainage and small openings. FDA approved.



SCANBELT
...keeping industry moving...

SUGGESTED INDUSTRIES



STANDARD FEATURES

Belt surface	Perforated flat top with 1 mm ribs
Open area	9 % Open area. Biggest opening 1,5 x 6 mm
Strength	Ideal choice for medium to heavy-duty transportation
Cleanability	Excellent. FSIS
Standard width	Increments of 10 mm, e.g. 100, 110 mm etc.

BELT DATA

Belt materials	Temperature range		Max. belt pull kg/m of width	Belt weight kg/m ²	Belt weight kg/m ² w. steel rods	Standard Colours
	Min.	Max.				
PE	- 73	66	1790	7	11	Blue/Natural
PP	+ 5	100	2400	7	11	Blue/White/Grey
POM	- 43	95	3600	11	15	Blue/Natural

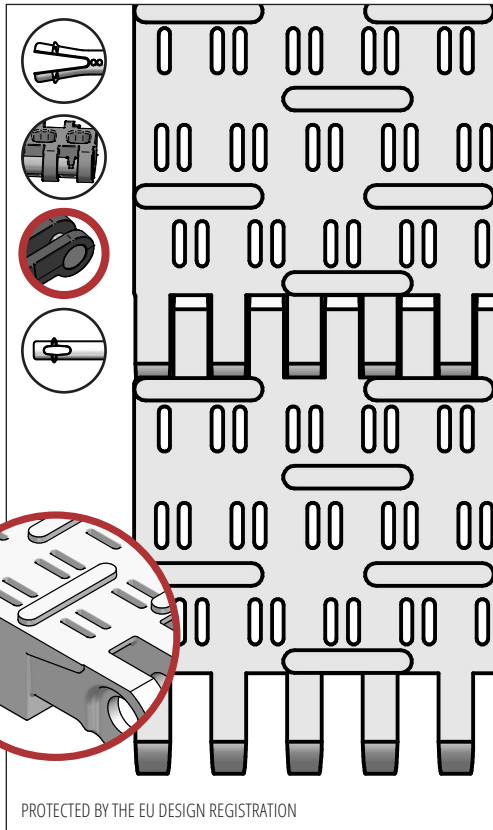

ACCESSORIES

Type	mm
Flights	25*, 50*, 75*, 100*
Scoop Flights	50, 75, 100*, 150*
Bent Flights	75*, 100*
Supported Flights	75, 100, 150
Flights fitted with a Round Top	Yes
Side Guard	50, 75, 100, 150
Friction Top	Yes
Hold-downs	Yes

*Modules can be supplied with a moulded indent of 40 mm.

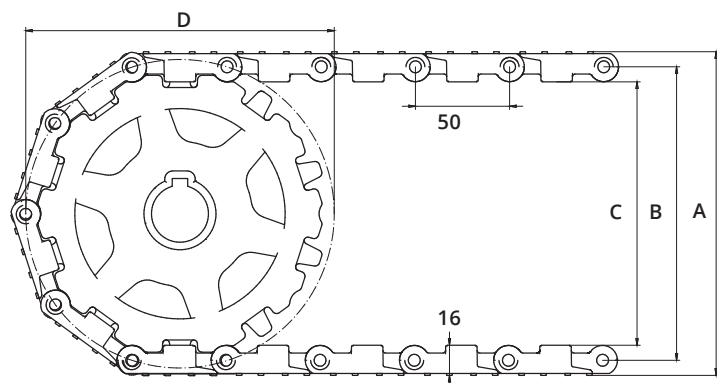

SPROCKET DATA

A = Outside, B = Pitch, C = Inside, D = Pitch Circle Diameter

No. Teeth	A mm	B mm	C mm	D mm	Hub Width mm	Round Bore		Square Bore	
						mm	Inch	mm	Inch
6	104	88	72	101	20	25 / 30 / 40	¾ / 1 / 1¼	25 / 40	1½
8	138	122	106	133	35	25 / 30 / 40	1 / 1¼	25 / 40	1½
10	172	156	140	164	35	25 / 30 / 40	1 / 1¼	20 / 25 / 40 / 60 / 50 / 60 / 80	1½ / 2½
12	205	189	173	195	35	25 / 30 / 40 / 50 / 60	1 / 1¼	25 / 40 / 60 / 80	1½ / 2½
16	270	254	238	258	35	60 / 80		40 / 60 / 80	